

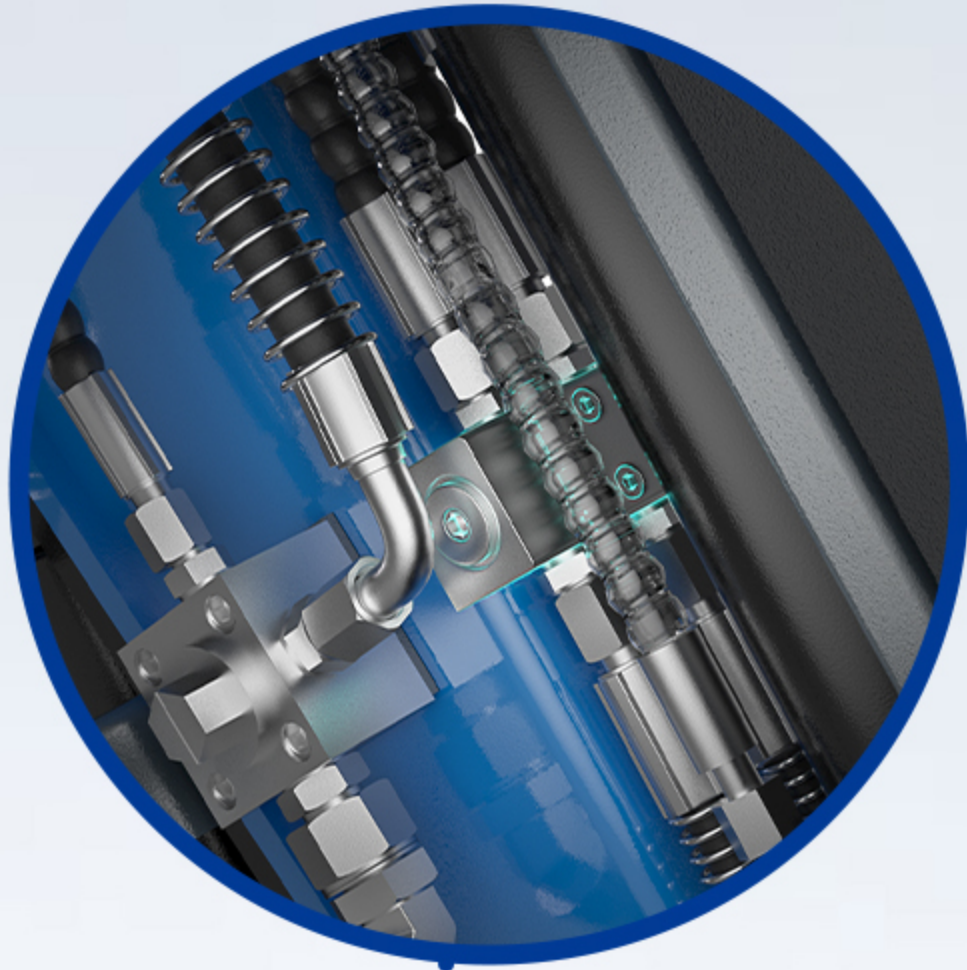

Hydraulic quick-change switch



Add high beam lights to the roof



High and low speed walking



5mm thermal insulation cotton

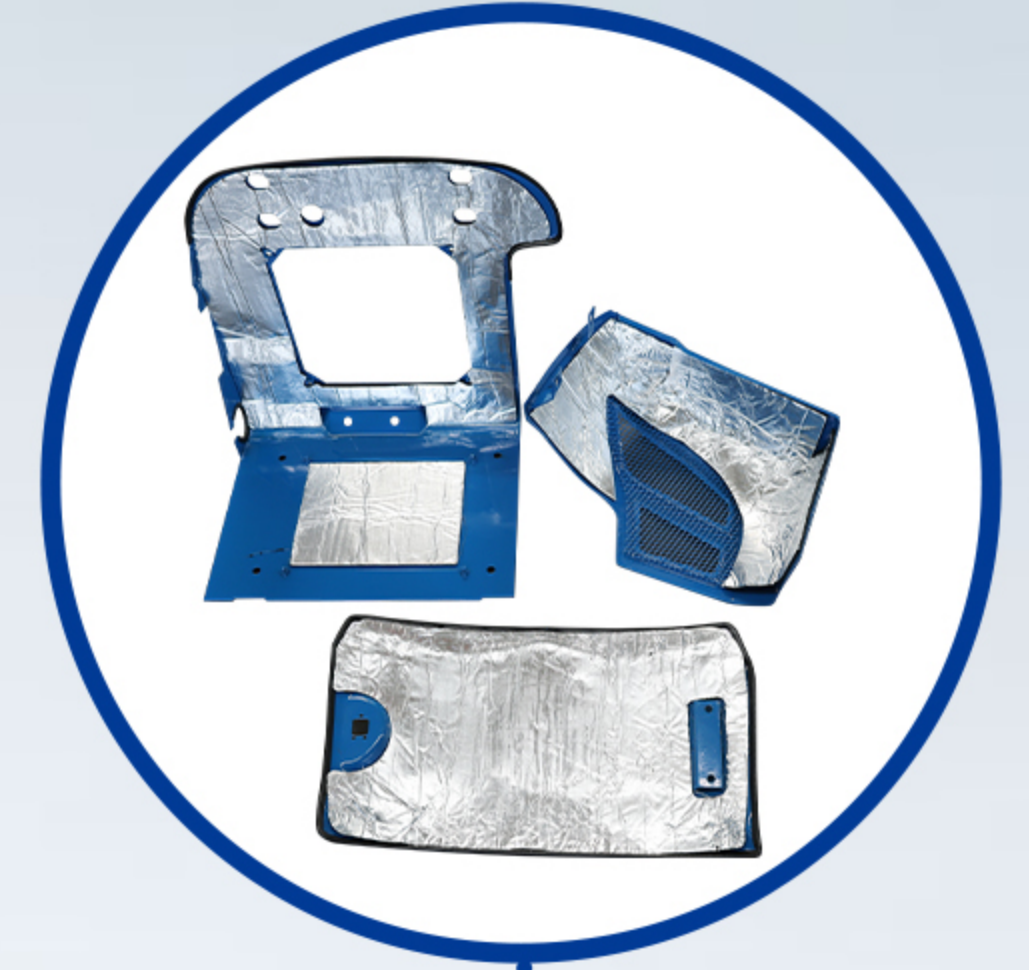

Kubota Engine D722

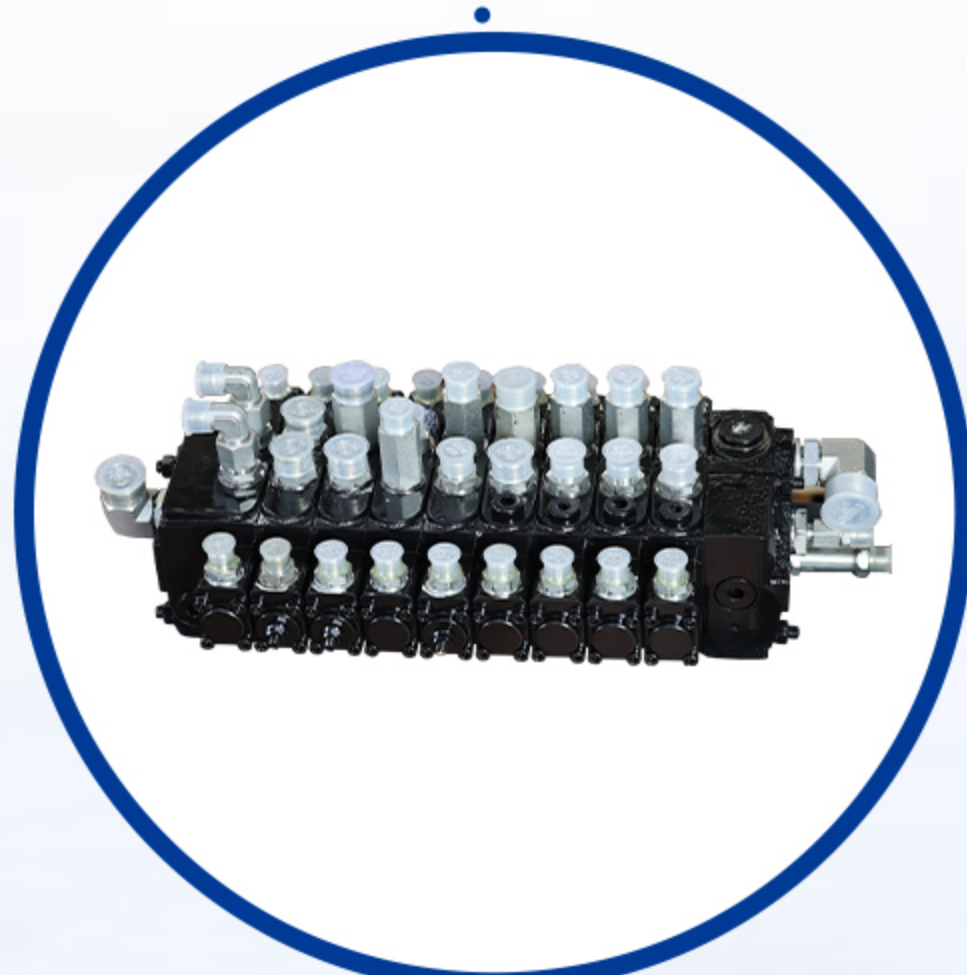

9-way pilot valve



Counterweight-Real

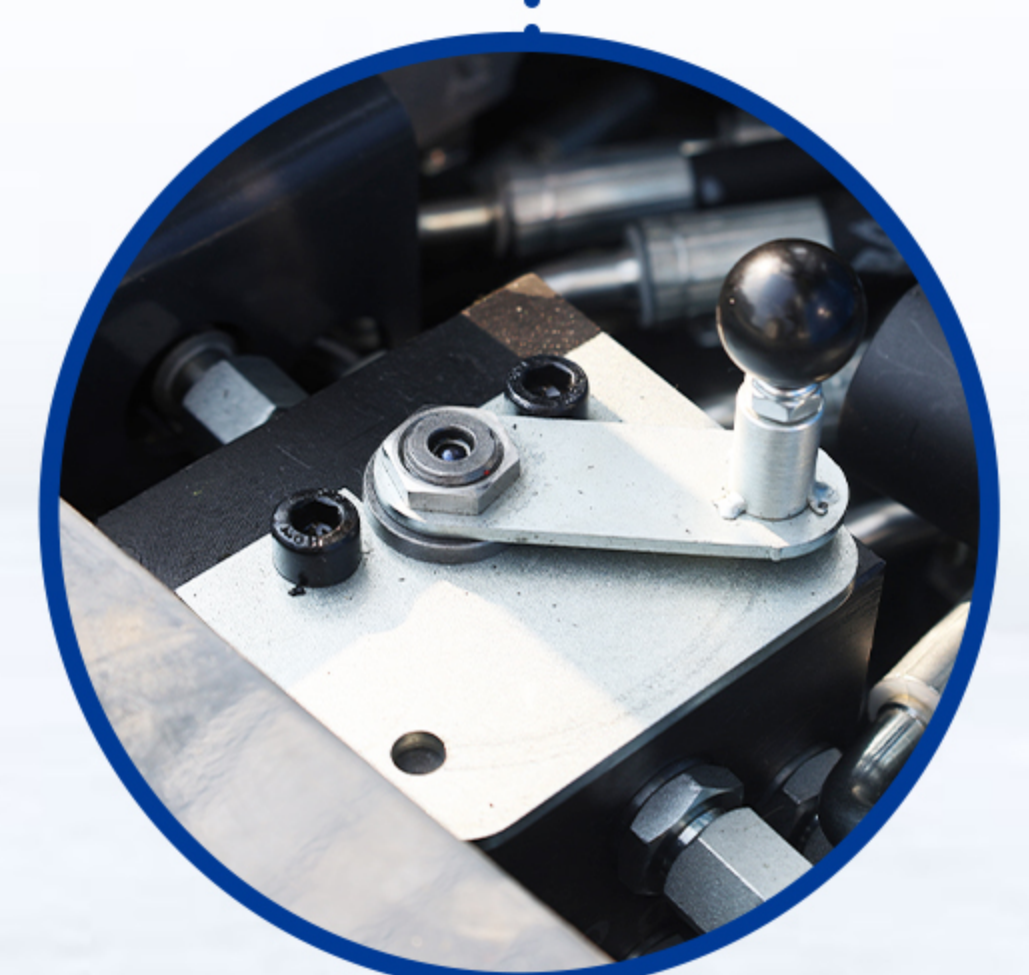

Forehand and backhand switching device

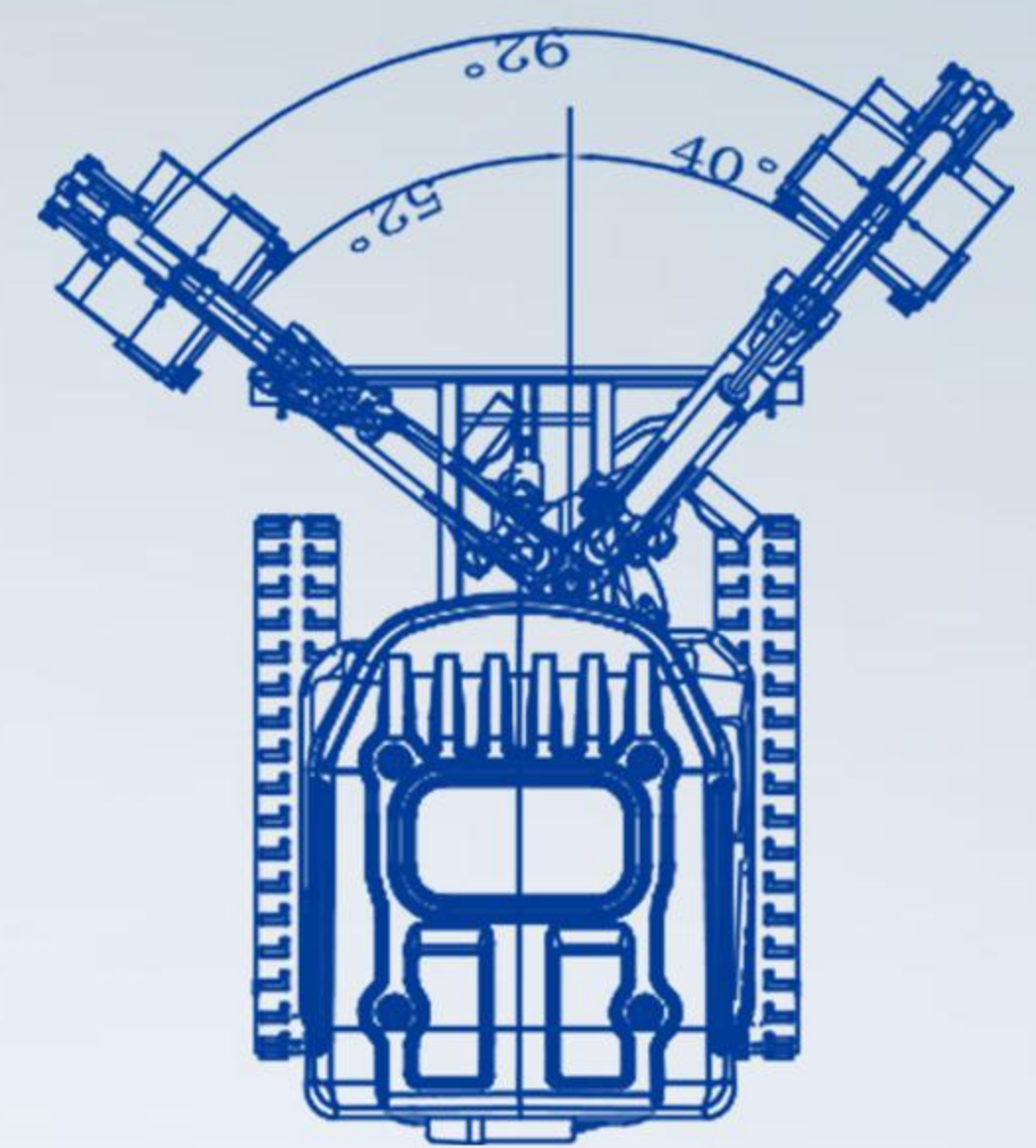
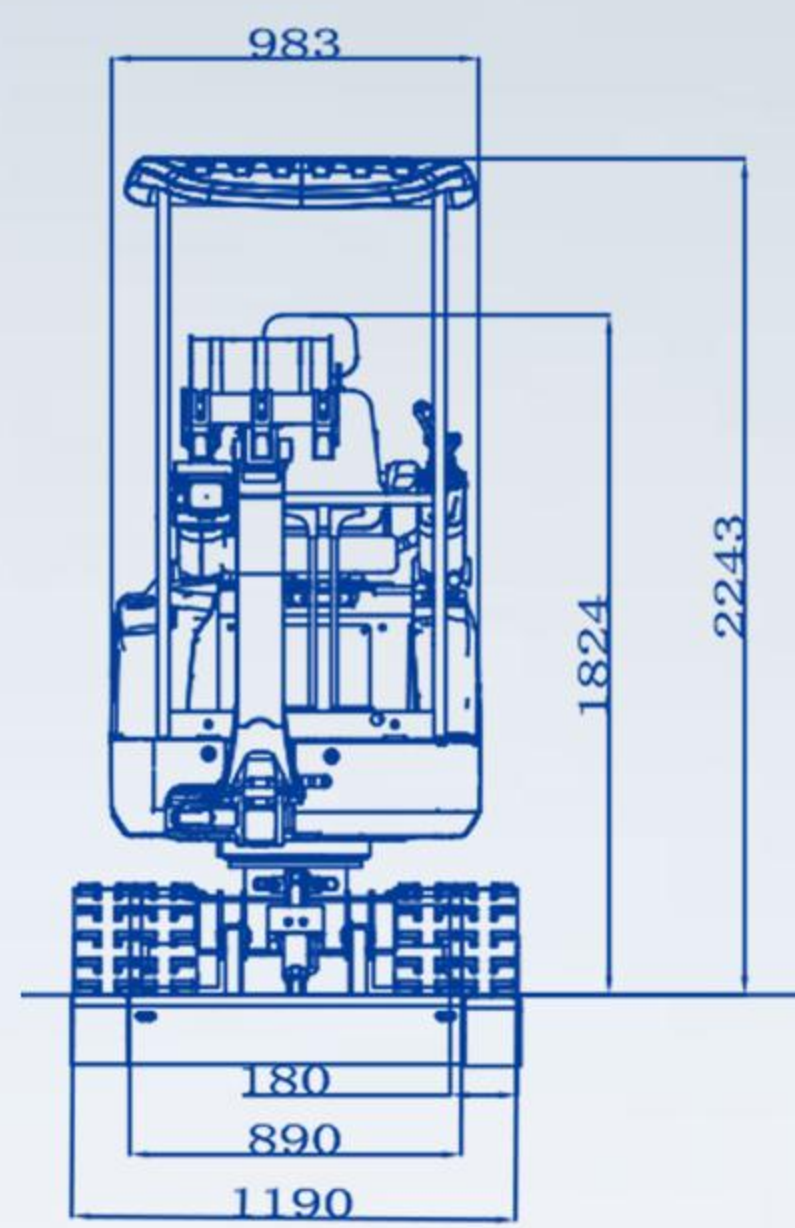
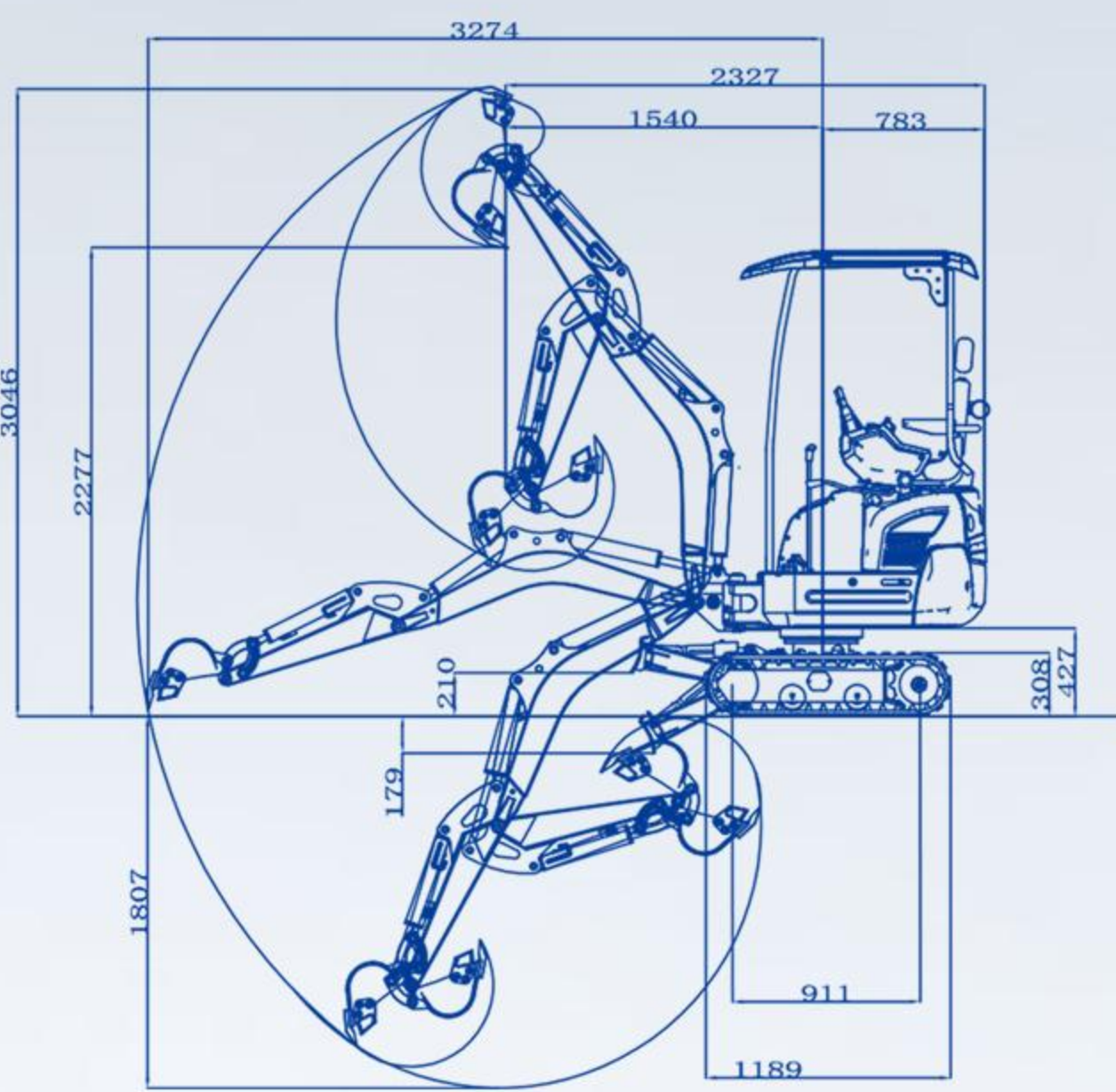

Unit: mm

## Basic parameters

Machine working weight	3179lb	1445kg
Bucket capacity	0.64ft <sup>3</sup>	0.018m <sup>3</sup>
Travel speed low/high speed	0-0.93/0-1.6mph	0-1.5/0-2.5km/h
Gradeability	30%	30%
Ground pressure	4.6psi	31.4kpa
Maximum digging force	2338lbf	10.4KN
Maximum digging radius	128.9in	3274mm
Maximum digging depth	71.1in	1807mm
Maximum digging height	119.9in	3046mm
Maximum unloading height	89.6in	2277mm
Maximum deflection angle	92°	92°
Track extension range	35.4-47.2in	900-1200mm
Engine brand	Kubota	Kubota
Engine model	D722	D722
Maximum horsepower	13.7hp	13.9PS
Maximum power	10.2kw	10.2KW
Maximum speed	2500rpm	2500rpm
Displacement	0.19gal	0.719L
Number of cylinders	3	3
Cooling method	Water-cooled	Water-cooled
Engine oil change amount	0.66gal	2.5L
Fuel form	Diesel	DIESEL
Fuel grade	0/-10	0/-10
Theoretical fuel consumption	1.1-1.5L	1.1-1.5L

## Body

Transport length	91.6in	2327mm
Transport width	38.7in	983mm
Transport height	88.3in	2243mm
Counterweight ground clearance	16.7in	427mm
Bucket width	15.7in	400mm
Boom length	58.1in	1477mm
Arm length	31.5in	800mm
Bulldozer blade width	40.3in	1024mm

## Hydraulic system

Maximum set pressure	2611psi	18MPa
Travel hydraulic motor type	WDM-300	WDM-300
Travel motor brand	Paiyi	Paiyi
Motor displacement	300ml/r	300ml/r
Slewing hydraulic motor type	BM2-315	BM2-315
Displacement	315ml/r	315ml/r
Main pump type/model	Gear pump/308-303	
Main pump brand	Tianjin Walking/Shengjie	
Main pump maximum flow	5.7GPM	21.6L/min
Multi-way valve	9-way pilot multi-way valve	
Multi-way valve brand	Tengfei/Shengjie	Tengfei/Shengjie
Rated set pressure	2466psi	17MPa

## SCENARIO APPLICATION

The RIPPA R15 is a 1.5-ton mini excavator built for safety and efficiency. It features a pilot lock system, ROPS canopy, and two-speed travel. Compact yet powerful, it's ideal for utility trenching, landscaping, light demolition, farm use, and urban construction. The reinforced canopy offers operator protection in challenging job sites.

Dealer / Name:

WhatsApp / Phone:

Address:

Email: